



1200MHz DIGITAL TRANSCEIVER

ID-1

D-STAR

DIGITAL

DV + DD

Digital Voice + Digital Data

10	0	150	33
255	0	0	0
10	0	150	

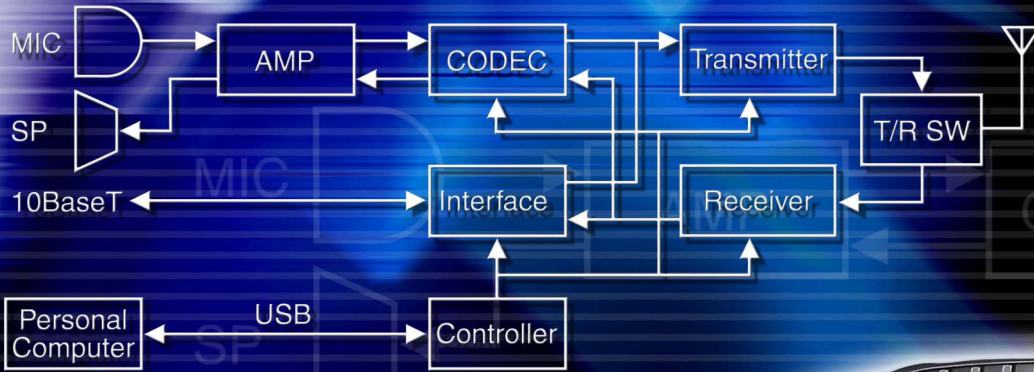

Icom Inc.

DIGITAL HAM INNOVATION

WITH DIGITAL VOICE & HIGH SPEED DATA

What is D-STAR?

D-STAR is a new ham radio system which offers digital voice and data communication. It connects repeater sites over microwave links and the Internet and forms a wide area ham radio network. The D-STAR system provides a new capability and functionality to the ham radio world and increases the efficiency of emergency communications.

What can the D-STAR system do?

128kbps digital data and 4.8kbps digital voice communication

The D-STAR system provides not only digital voice (DV mode) communication but also digital data transmission (DD mode). It can exchange various data files such as graphics, images, etc, at 128kbps.



Your voice and data can reach further than ever

Multiple repeater links by radio and the Internet provide long distance communication to virtually anywhere.

Internet application available

The D-STAR system uses the TCP/IP protocol, so when connected with a PC, web, e-mail and other Internet applications are available.

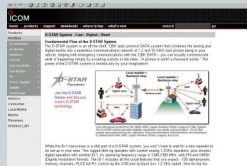

Wireless Internet Access

No matter where you travel within the D-STAR network, you can access the web, e-mail, text messages and multimedia messages.



Independent network

In DD mode, ID-1 can transfer data directly with another ID-1 without the use of a repeater. This is useful for establishing a simple network where a D-STAR repeater does not exist or D-STAR services are not required.

Increase efficiency of emergency communications

Out in the field, fast emergency information is the key. Send pictures and weather charts to or from a remote location with the ID-1. "A picture is worth a thousand words", and efficient send/receive opens up your repeater for other emergency communications.

D-STAR system will be upgraded

The D-STAR system will be enhanced and new D-STAR radios will be released, adding features and performance to the D-STAR system.

D-STAR repeater system

The D-STAR repeater is composed of a repeater controller, digital voice repeater(s), data repeater, 10GHz microwave relay and the Internet gateway PC. For the signal is digital, no information is lost due to conversion and multiple repeater relays are possible in this system. The D-STAR system repeater can perform 3 relay functions as shown in the following figures.

Single repeater

The D-STAR repeater operates similar to existing analog repeater. That is a simple relay of transmit and receive communication. In DV mode, cross band (144/440/1200MHz) operation is also possible.

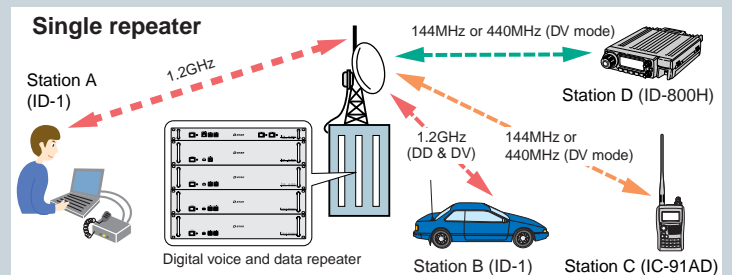

Microwave link

When D-STAR repeaters are connected via 10GHz microwave, the D-STAR system transfers received data to another repeater site. You can also make a CQ call to a specified repeater area.

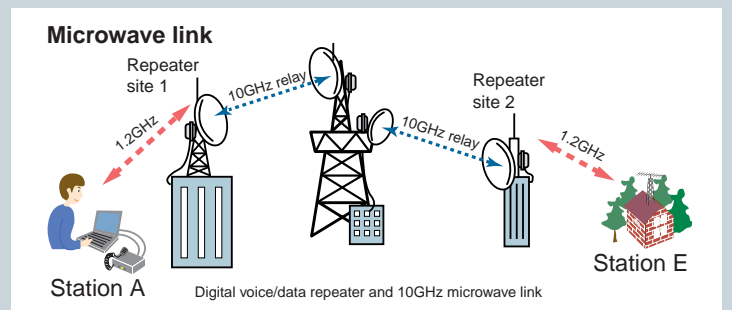

Internet gateway relay

When D-STAR repeaters are connected with the Internet gateway, the D-STAR system relays the received data over the Internet. Microwave links and Internet gateways can be combined even during one contact. So your message will get through virtually to anywhere in the D-STAR system.

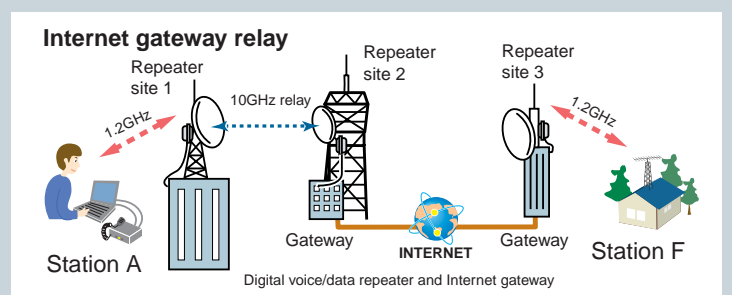

PC remote controller supplied

The controller software is supplied with the ID-1. When the ID-1 is connected to a PC via a USB cable, most functions of the ID-1 can be controlled from the PC. In DD mode operation*, you can browse web sites and send and receive e-mail as if the ID-1 is a 10W wireless network adapter. * Ethernet port is required for DD mode operation.

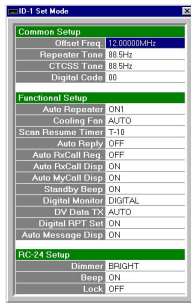
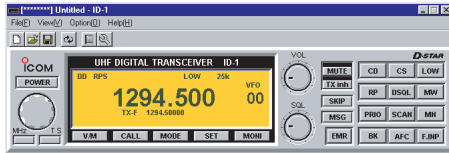

Useful callsign functions

The ID-1 embeds your own and the called station's callsign in your transmission. When you input "CQCQCQ" as the intended station, you can make a CQ call in the area. The calling station's ID is displayed on the received station and a newly received callsign can be automatically stored in the memory.

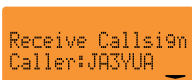

Received callsign example

Digital callsign squelch (DSQL) & Digital code squelch (CSQL)

The DSQL opens the squelch, only when

your callsign is received. When you share a single callsign with a club or group members, the CSQL function allows you to set a CSQL code from 00 to 99 and provides quiet stand-by while other members are talking.

EMR mode operation

When you require the attention of all stations in the area, the Enhanced Monitor Request (EMR) mode operation allows the caller to bypass the CSQL and DSQL setting of the receivers station. During EMR mode operation, all receiving stations will hear your audio, even though they may be muted.

Short message in DV mode

Short messages of 20 characters max. can be sent in DV mode operation.

Analog FM mode operation

The ID-1 also operates in analog FM mode, allowing you to communicate with an analog FM transceiver. In FM mode operation, the ID-1 has CTCSS tone squelch and pocket beep functions for quiet stand-by.

Other features

- 950bps (approx.) data communication capability in DV mode
- AFC (Automatic Frequency Control) function*
- S-meter squelch
- Break-in communication
- Programmed, memory and select mode scan
- Stand-by beep

* FM and digital voice only.

Rear View

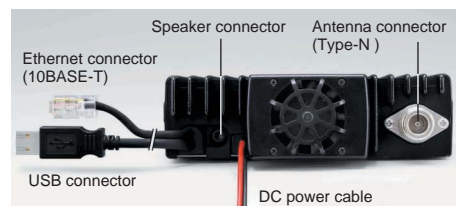

DV+DD

Digital Voice + Digital Data

1200MHz DIGITAL TRANSCEIVER ID-1



SPECIFICATIONS

GENERAL

- Frequency coverage : 1240–1300MHz
- Type of emission : FM, GMSK (Digital)
- Transmission speed (theoretical value) :
Data 128kbps
Digital voice 4.8kbps
- Codec : AMBE (2.4kbps)
- No of memory channels: 100 regular 3 calls and 2 scan edges
- Frequency resolution : 5, 6.25, 10, 12.5, 20, 25, 50, 100kHz
- Operating temp. range: -10°C to +60°C; +14°F to +140°F
- Frequency stability : ±2.5ppm (-10°C to +60°C)
- Power supply requirement : 13.8V DC ±15%
- Current drain (at 13.8V DC; approx.):
Rx AF max. Less than 1.5A
Tx at 10W Less than 7.0A
- Antenna impedance : 50Ω (Type-N)
- Dimensions (Projections not included; W×H×D) :
Main unit 141 × 40 × 165.8 mm;
5⁹/₁₆ × 1⁹/₁₆ × 6¹⁷/₃₂ in
Remote controller 150 × 50 × 49.5 mm;
5²⁹/₃₂ × 1³¹/₃₂ × 1¹⁵/₁₆ in
- Weight (approx.) :
Main unit 1.2kg; 2.6lb
Remote controller 220g; 7.7oz

TRANSMITTER

- Modulation system :
FM Variable reactance modulation
Digital Quadrature modulation
- Output power : 10W/1W (Selectable)
- Max. frequency deviation: ±5.0kHz (FM)
- Spurious emissions : Less than -50dB
- Microphone connector : 8-pin modular jack (600Ω)

RECEIVER

- Intermediate frequency:
FM, Digital voice 243.95MHz/31.05MHz/450kHz
(1st/2nd/3rd)
- Sensitivity (FM: at 12dB SINAD, Digital: at BER 1×10⁻²) :
Data 243.95MHz/10.7MHz (1st/2nd)
FM Less than 0.18μV
Digital Voice Less than 0.35μV
Data Less than 1.58μV
- Squelch sensitivity : Less than 0.18μV (FM, threshold)
- Selectivity (typical) :
FM More than 12kHz/6dB
Less than 30kHz/60dB
Digital voice More than 6kHz/6dB
Less than 18kHz/50dB
Data More than 140kHz/6dB
Less than 520kHz/40dB

- Spurious and image rejection : More than 50dB
- Audio output power : More than 2.0W at 10% distortion (at 13.8V DC) with 8Ω load
- Ext. speaker connector : 2-conductor 3.5 (d) mm (1/8)/8Ω

Supplied accessories: (* Optional for some versions.)

- Microphone
- External speaker, SP-22
- Ethernet cable coupler
- DC power cable
- USB extension cable (1.5 m; 4.9 ft)
- Ethernet cable (3 m; 9.8 ft)
- Remote controller (RC-24)*
- Controlling software CD
- Mic extension cable (2.5 m; 8.2 ft)*
- Mounting bracket kit for RC-24*

System requirements for controller software:

- Microsoft® Windows® 98/98SE/Me/2000/XP
- USB Port
- Ethernet port (for DD mode operation)

Applicable U.S. Military Specifications

Standard	MIL 810 C		MIL 810 D		MIL 810 E		MIL 810 F	
	Method	Proc.	Method	Proc.	Method	Proc.	Method	Proc.
Low Pressure	500.1	I	500.2	I, II	500.3	I, II	500.4	I, II
High Temp.	501.1	I	501.2	I, II	501.3	I, II	501.4	I, II
Low Temp.	502.1	I	502.2	I, II	502.3	I, II	502.4-3	I, II
Temp. Shock	503.1	I	503.2	I	503.3	I	503.4	I
Solar Radiation	505.1	I	505.2	I	505.3	I	505.4	I
Humidity	507.1	I, II	507.2	II, III	507.3	II, III	507.4	-
Salt Fog	509.1	I	509.2	I	509.3	I	509.4	-
Dust	510.1	I	510.2	I	510.3	I	510.4	I
Vibration	514.2	VIII, X	514.3	I	514.4	I	514.5	I
Shock	516.2	I, II, V	516.3	I, IV	516.4	I, IV	516.5	I, IV

OPTIONS



• **HM-154**
HAND MICROPHONE
Regular hand microphone.



• **OPC-440**
MIC EXTENSION CABLE
5m (16.4ft)



• **RC-24** REMOTE
CONTROLLER UNIT
Same as supplied with some
versions.



• **SP-10**
EXTERNAL SPEAKER



• **SP-22**
EXTERNAL SPEAKER
Same as supplied

All trademarks are the properties of their respective holders.

D-STAR REPEATER



• **ID-RP2C** REPEATER
CONTROLLER
Connect to ID-RP2V, ID-RP2D,
ID-RP2L and/or Gateway PC.



• **ID-RP2V** 1.2GHz DIGITAL
VOICE REPEATER



• **ID-RP2D** 1.2GHz DATA
REPEATER



• **ID-RP2L** 10GHz MICRO-
WAVE LINK REPEATER

SYSTEM OVERVIEW

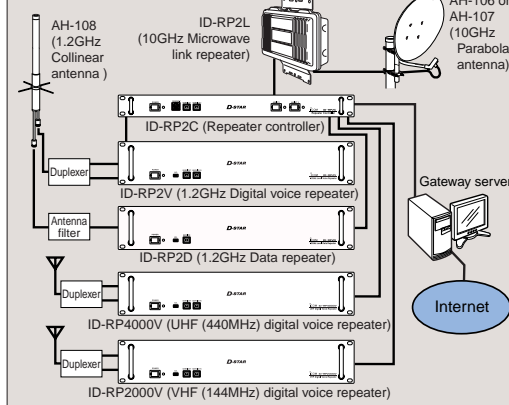

AH-108

AH-106

AH-107



▲ **AH-106** PARABOLA ANTENNA (ø800mm)
AH-107 PARABOLA ANTENNA (ø450mm)
For connection with ID-RP2L. Max. communication
range, AH-106 to AH-106: 20km, AH-106 to
AH-107: 12km, AH-107 to AH-107: 8km
* Ranges may differ depending on weather condi-
tions, etc. All ranges are approximation.
◀ **AH-108** 1.2GHz COLLINEAR ANTENNA
Built-in dual collinear antennas for ID-RP2V
and ID-RP2D.

Les spécifications et informations données dans ce document peuvent être modifiées sans préavis.

ICOM FRANCE

Zac de la Plaine - 1, Rue Brindejonc des Moulinais
BP 45804 - 31505 TOULOUSE CEDEX 5
Tél : 05 61 36 03 03 - Fax : 05 61 36 03 00
WEB ICOM : <http://www.icom-france.com>
E-mail : icom@icom-france.com



CACHET REVendeur

